

APPLICATION

For use in equipment insulated with air, typically for transformers, switchgear, capacitors...

TECHNICAL CHARACTERISTICS

Each bushing is tested for AC withstand and partial discharge prior to leaving the factory.



DESIGN

The equipment bushing is a moulded epoxy insulated part in accordance with CENELEC EN 50181.

Non-tracking insulating rubber boot and collars slip over the bushing shank.

SPECIFICATIONS AND STANDARDS

The bolted type equipment bushings 672TBC meet the requirements of IEC 60137.

ORDERING INSTRUCTIONS

To order the equipment bushing, specify the type.

For use in potentially explosive atmospheres (for 12 kV max.).

Order: -/ATEX.

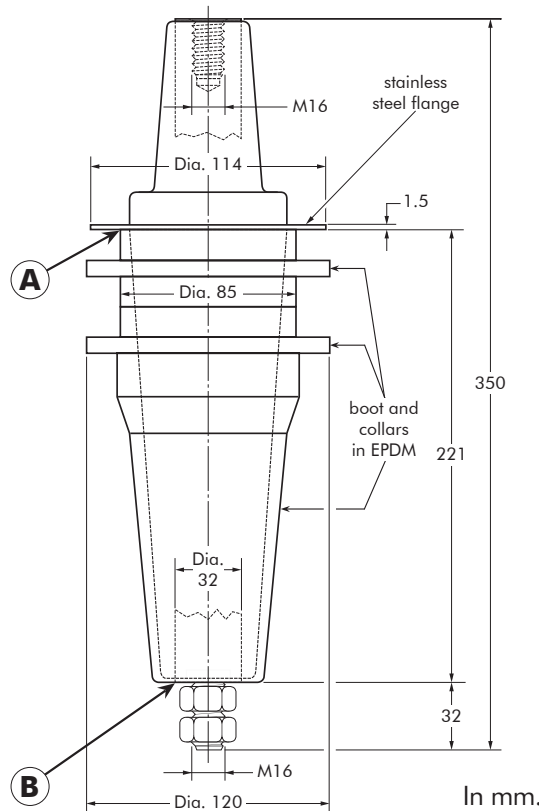

6/10 (12) kV
6.35/11 (12) kV
8.7/15 (17.5) kV
12/20 (24) kV
12.7/22 (24) kV

Up to 24 kV - 1250 A

EUROMOLD®

Equipment bushing type	Voltage U_m (kV)	Current I_r (A)	Creepage distance A-B (mm)
672TBC	12	1250	300
K672TBC	24	1250	300

FIXINGS FOR EQUIPMENT BUSHINGS

672TBC BUSHING

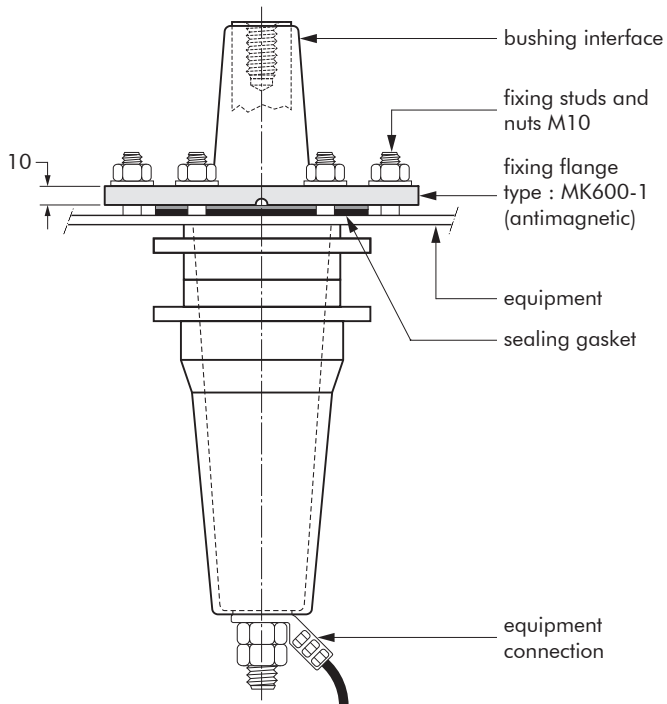

BUSHING FIXING FLANGE

To order the bushing fixing flange, simply specify MK600-1.

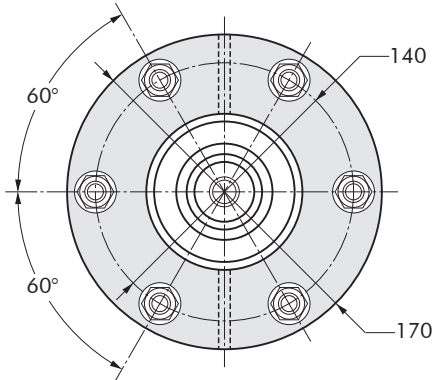

In mm.