

400SFR-P

INTERFACE B EQUIPMENT BUSHING

APPLICATION

For use in equipment insulated with SF₆ gas.

TECHNICAL CHARACTERISTICS

Each bushing is tested for AC withstand and partial discharge prior to leaving the factory.



DESIGN

The equipment bushing is a moulded epoxy insulated part with a connector interface in accordance with CENELEC EN 50181. The 400SFR-P bushing has a shank outside this standard, adapted for use in SF₆ gas.

SPECIFICATIONS AND STANDARDS

The plug-in type equipment bushing 400SFR-P meets the requirements of CENELEC EN 50180 and IEC 60137.

ORDERING INSTRUCTIONS

To order the equipment bushing, simply specify the type.

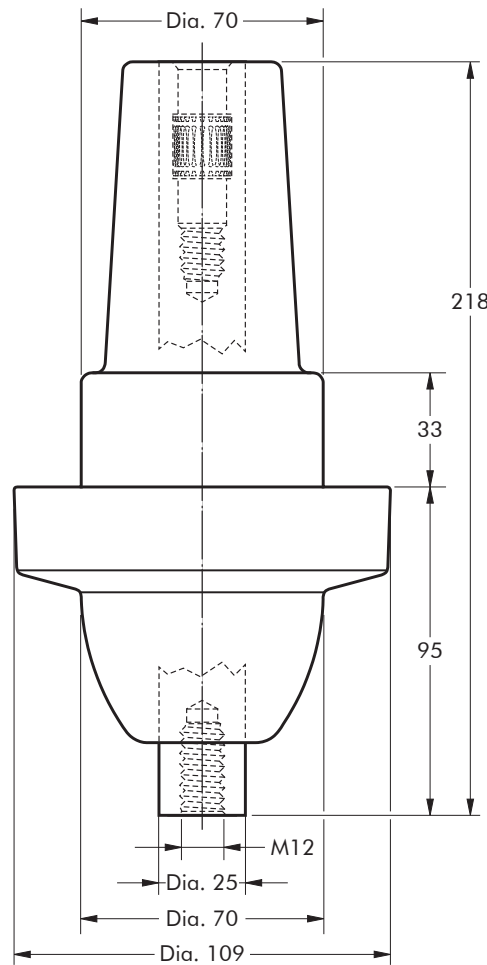

In mm.

6/10 (12) kV
6.35/11 (12) kV
8.7/15 (17.5) kV
12/20 (24) kV
12.7/22 (24) kV

Up to 24 kV - 400 A

EUROMOLD®

Equipment bushing type	Voltage U _m (kV)	Current I _r (A)
400SFR-P	12	400
K400SFR-P	24	400

05/2017

FIXINGS FOR EQUIPMENT BUSHINGS

400SFR-P BUSHING FOR GAS INSULATED SWITCHGEAR

