

CAUTION : Read instructions thoroughly and completely prior to beginning installation.

Installation Instructions

(K),(M)400T1 & (K),(M)400AR-1
Equipment Bushing - Type B interface - 400 A - Up to 36 kV

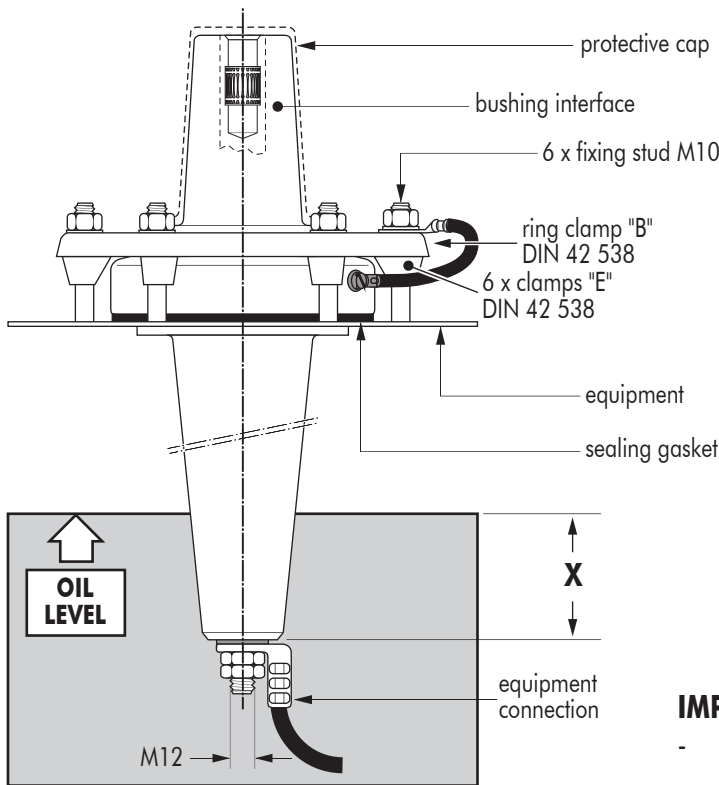

(K),(M)400T1/J & (K),(M)400AR-1/J equipment bushings with earthing jumper

Typical fixing with Ring Clamp DIN 42 538

MINIMUM OIL LEVEL

System voltage	X Length
6/10 kV	40 mm
12/20 kV	50 mm
18/30 kV	75 mm

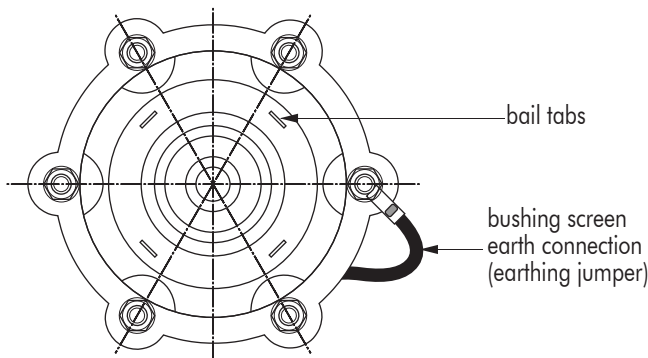

IMPORTANT NOTES :

- Euromold bushings are supplied with protective caps over the mating interface offering protection against mechanical damage and the ingress of any contaminant. Under no circumstances should this shipping cap be considered as an electrical dead ending device.
- Euromold bushings should never be energised in isolation neither should they be disconnected whilst energised. They should always be connected to one of the recommended mating parts or the electrical dead-ending device : 400DR, K400DR, M400DR, 400DR/G, K400DR/G or M400DR/G.
- Do not paint the interface.

Euromold
a Nexans company

This product should be installed only by competent personnel trained in good safety practices involving high voltage electrical equipment. These instructions are not intended as a substitute for adequate training or experience in such safety practices. These instructions do not attempt to provide for every possible contingency. Failure to follow these instructions could result in damage to the product and serious or fatal injury. IMPORTANT : Cable and associated apparatus must be de-energised, locked out, and tagged prior to product installation.

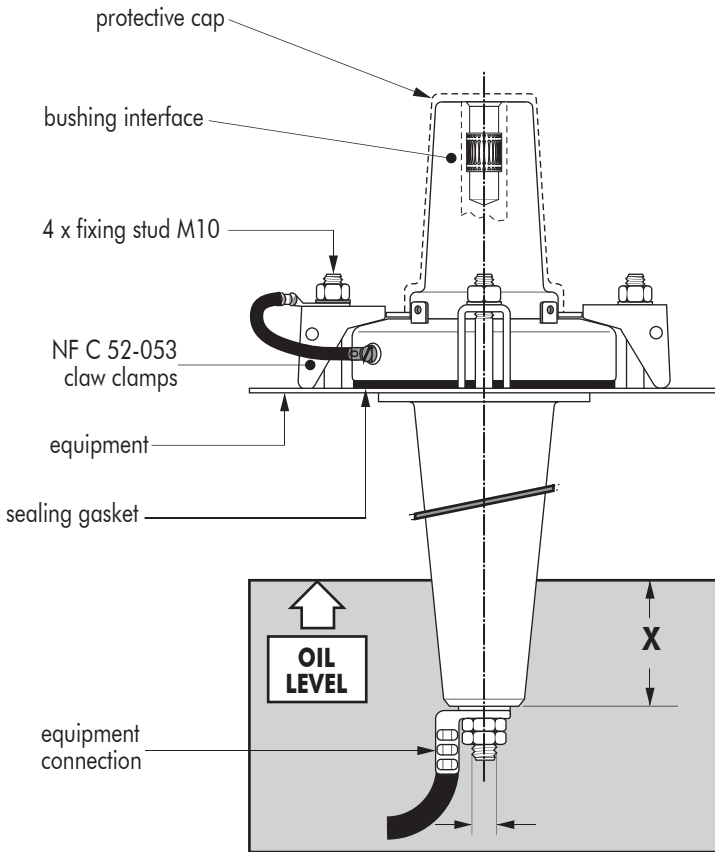

(K),(M)400T1/J & (K),(M)400AR-1/J equipment bushings with earthing jumper

Typical fixing with Claw Clamps NF C 52-053

MINIMUM OIL LEVEL

System voltage	X Length
6/10 kV	40 mm
12/20 kV	50 mm
18/30 kV	75 mm

(K),(M)400T1/GS & (K),(M)400AR-1/GS equipment bushings with earthing plate

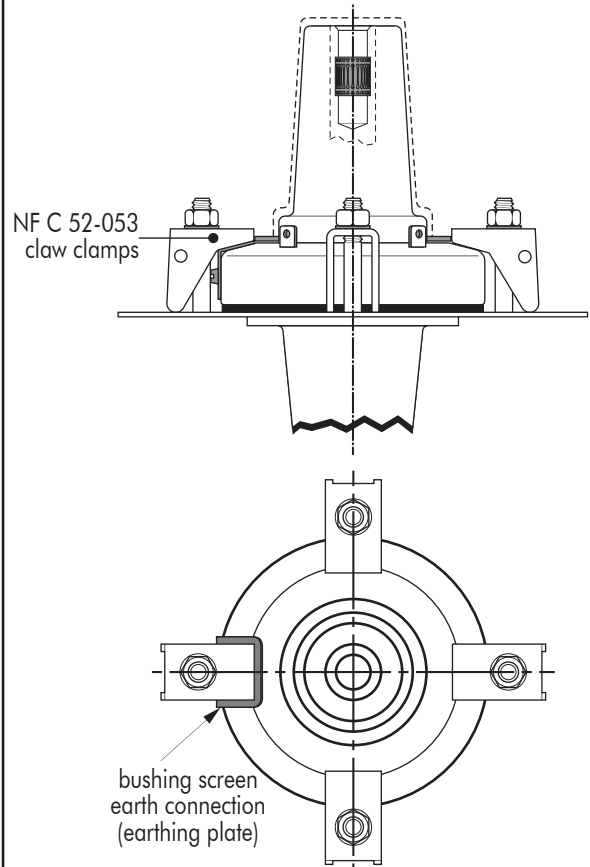

IMPORTANT NOTES :

- Euromold bushings are supplied with protective caps over the mating interface offering protection against mechanical damage and the ingress of any contaminant. Under no circumstances should this shipping cap be considered as an electrical dead ending device.
- Euromold bushings should never be energised in isolation neither should they be disconnected whilst energised. They should always be connected to one of the recommended mating parts or the electrical dead-ending device : 400DR, K400DR, M400DR, 400DR/G, K400DR/G or M400DR/G.
- Do not paint the interface.

Euromold
a Nexans company

Nexans Network Solutions NV - div. EUROMOLD

Zuid III - Industrielaan 12
B-9320 EREMBODEGEM-AALST – BELGIUM
Tel: +32 (0)53/85 02 11 – Telefax: +32 (0)53/83 10 13

FOR INFORMATION ONLY Please always use the instructions supplied in the kit