

# 400PB-10SA

## INTERFACE C SURGE ARRESTER

### APPLICATION

Surge arrester designed to protect medium voltage components, including transformers, equipment, cable and accessories from high voltage surges resulting from lightning or switching.

### DESIGN

Surge arrester comprising:

1. Conductive EPDM insert.
2. Conductive EPDM jacket.
3. Insulating EPDM layer moulded between the insert and the jacket.
4. Contact rod.
5. Earthing lead.
6. Earth connection.
7. Steel cap.
8. Metal oxide valve elements.
9. Type C interface as described by CENELEC EN 50180 and 50181.

### SPECIFICATIONS AND STANDARDS

- The 400PB-10SA surge arresters meet the test requirements of IEC 60099-4.
- Station class (SL);  $Q_{rs} = 1.0$  As
- Energy absorption 4.0 kJ/kV<sub>Ur</sub>

### TECHNICAL CHARACTERISTICS

- This surge arrester is a metal oxide varistor surge arrester in an elbow configuration.
- Each arrester is tested for AC withstand, partial discharge and critical voltage prior to leaving the factory.

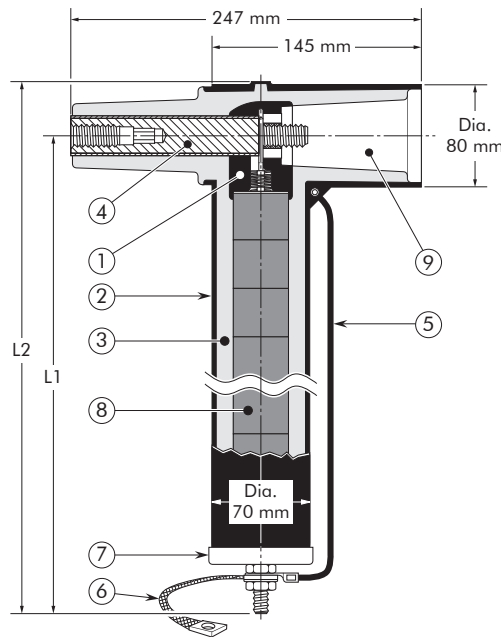

- 6/10 (12) kV
- 6.35/11 (12) kV
- 8.7/15 (17.5) kV
- 12/20 (24) kV
- 12.7/22 (24) kV
- 18/30 (36) kV
- 19/33 (36) kV
- 20.8/36 (42) kV

Up to 42 kV

**EUROMOLD®**

Surge arrester type	Nominal discharge current I <sub>n</sub> (kA)	Rated voltage U <sub>r</sub> (kV)	Max. continuous operating voltage U <sub>c</sub> (kV)	Dimensions (mm) (indicative)	
				L1	L2
400PB-10SA-6N	10	6	4.8	270	310
400PB-10SA-9N	10	9	7.2	270	310
400PB-10SA-12N	10	12	9.6	270	310
400PB-10SA-15N	10	15	12	270	310
400PB-10SA-18N	10	18	14.4	270	310
400PB-10SA-22N	10	22	17.6	270	310
400PB-10SA-24N	10	24	19.2	370	410
400PB-10SA-27.5N	10	27.5	22	370	410
400PB-10SA-30N	10	30	24	370	410
400PB-10SA-33N	10	33	26.4	370	410
400PB-10SA-36N	10	36	28.8	370	410
400PB-10SA-40N	10	40	32	470	510
400PB-10SA-42N	10	42	33.6	470	510
400PB-10SA-45N	10	45	36	470	510
400PB-10SA-51N	10	51	40.8	470	510

06/2022

## TYPICAL APPLICATIONS AND DIMENSIONS

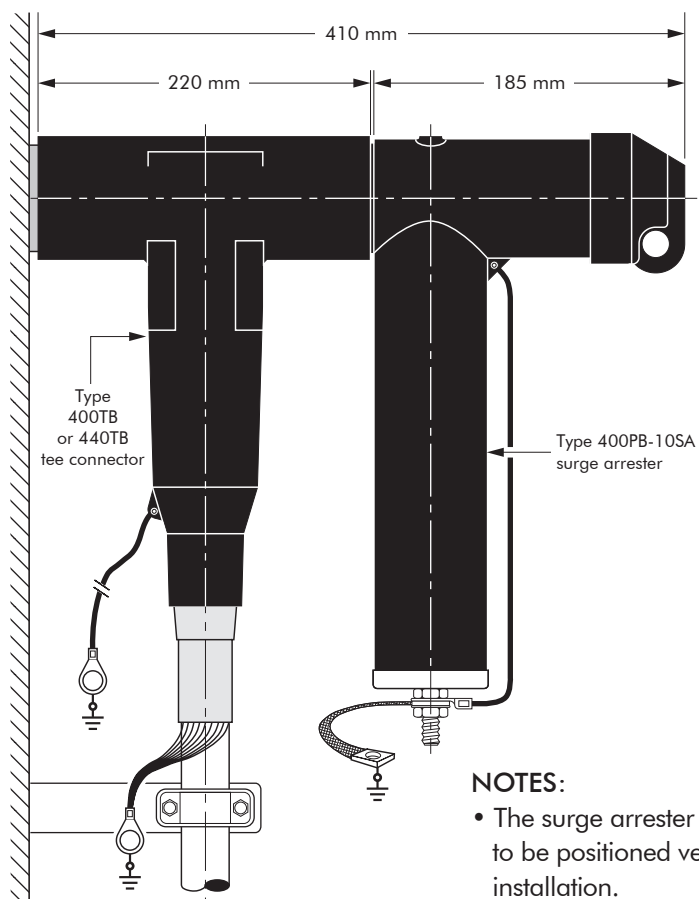

### NOTES:

- The surge arrester body needs to be positioned vertically after installation.
- Prior to cable testing, the surge arrester shall be removed.

## ORDERING INSTRUCTIONS

To order the surge arrester, specify the surge arrester type, as described on previous page.

### EXAMPLE:

For a maximum continuous operating voltage (r.m.s.) of 24 kV and a nominal discharge current of 10 kA. Order a 400PB-10SA-30N surge arrester.

## TECHNICAL DATA

Surge arrester type	Steep current residual voltage @ 10 kA [1/20 μs] (kV)	Lightning current residual voltage [8/20 μs] (kV)			Switching impulse residual voltage [36/90 μs] (kV)		High current impulse withstand (kA)
		@ 5 kA	@ 10 kA	@ 20 kA	@ 125 A	@ 500 A	
400PB-10SA-6N	18.5	16.2	17.2	19.3	12.6	13.2	100
400PB-10SA-9N	26.3	23	24.5	27.5	18.1	19.1	100
400PB-10SA-12N	36.3	31.5	33.6	37.1	25.1	26.5	100
400PB-10SA-15N	45.3	39.4	42	46.4	31.4	33.1	100
400PB-10SA-18N	54.4	47.3	50.4	56.4	37.7	39.7	100
400PB-10SA-22N	66.5	57.8	61.6	68.1	46	48.5	100
400PB-10SA-24N	72.5	63	67.2	75.2	50.2	53	100
400PB-10SA-27.5N	81.6	71	75.6	85	56.5	59.6	100
400PB-10SA-30N	90.7	78.8	84	94	62.8	66.2	100
400PB-10SA-33N	99.7	86.7	92.4	102.1	65	68.5	100
400PB-10SA-36N	108.8	94.5	100.8	112.7	75.3	79.4	100
400PB-10SA-40N	120.9	105.1	112	123.8	83.7	88.3	100
400PB-10SA-42N	126.9	110.3	117.6	130	87.9	92.7	100
400PB-10SA-45N	136	118.2	126	139.3	94.2	99.3	100
400PB-10SA-51N	154.1	134	142.8	160.4	106.7	112.5	100