

APPLICATION

Surge arrester designed to protect 12 and 24 kV class components, including transformers, equipment, cable and accessories from high voltage surges resulting from lightning or switching.

TECHNICAL CHARACTERISTICS

- This surge arrester is a metal oxide varistor surge arrester in an elbow configuration.
- Each arrester is tested for AC withstand and partial discharge prior to leaving the factory.



DESIGN

Surge arrester comprising:

1. Bail restraint.
2. Conductive EPDM insert.
3. Type A - 250 A interface as described by CENELEC EN 50180 and 50181.
4. Pin contact.
5. Contact disc.
6. Copper shunt.
7. Metal oxide valve elements.
8. Aluminium spacer.
9. Steel cap.
10. Earth connection.
11. Insulating EPDM layer moulded between the insert and the jacket.
12. Conductive EPDM jacket.

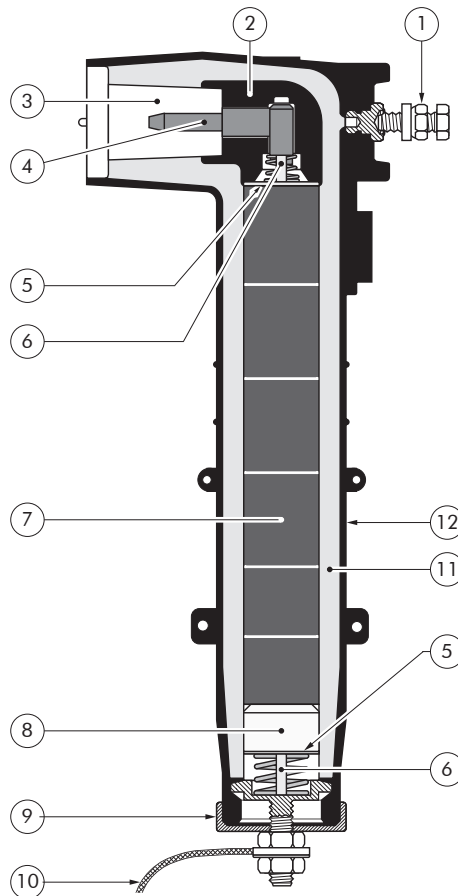

6/10 (12) kV
6.35/11 (12) kV
8.7/15 (17.5) kV
12/20 (24) kV
12.7/22 (24) kV

Up to 24 kV

EUROMOLD®

Surge arrester type	Nominal discharge current I_n (kA)	Rated voltage U_r (kV)	Max continuous operating voltage U_c (kV)	Steep current residual voltage @ 5 kA [1/20 μ s] (kV)	Lightning current residual voltage @ 5 kA [8/20 μ s] (kV)	High current impulse withstand (kA)
156SA-12	5	15	12.5	62.5	54.5	40
156SA-15	5	19	15.5	77.0	69.0	40
156SA-18	5	22	18.0	87.0	79.0	40
156SA-21	5	26	21.0	101.5	93.5	40
156SA-24	5	30	24.5	116.5	108.5	40

02/2020

TYPICAL APPLICATION AND DIMENSIONS

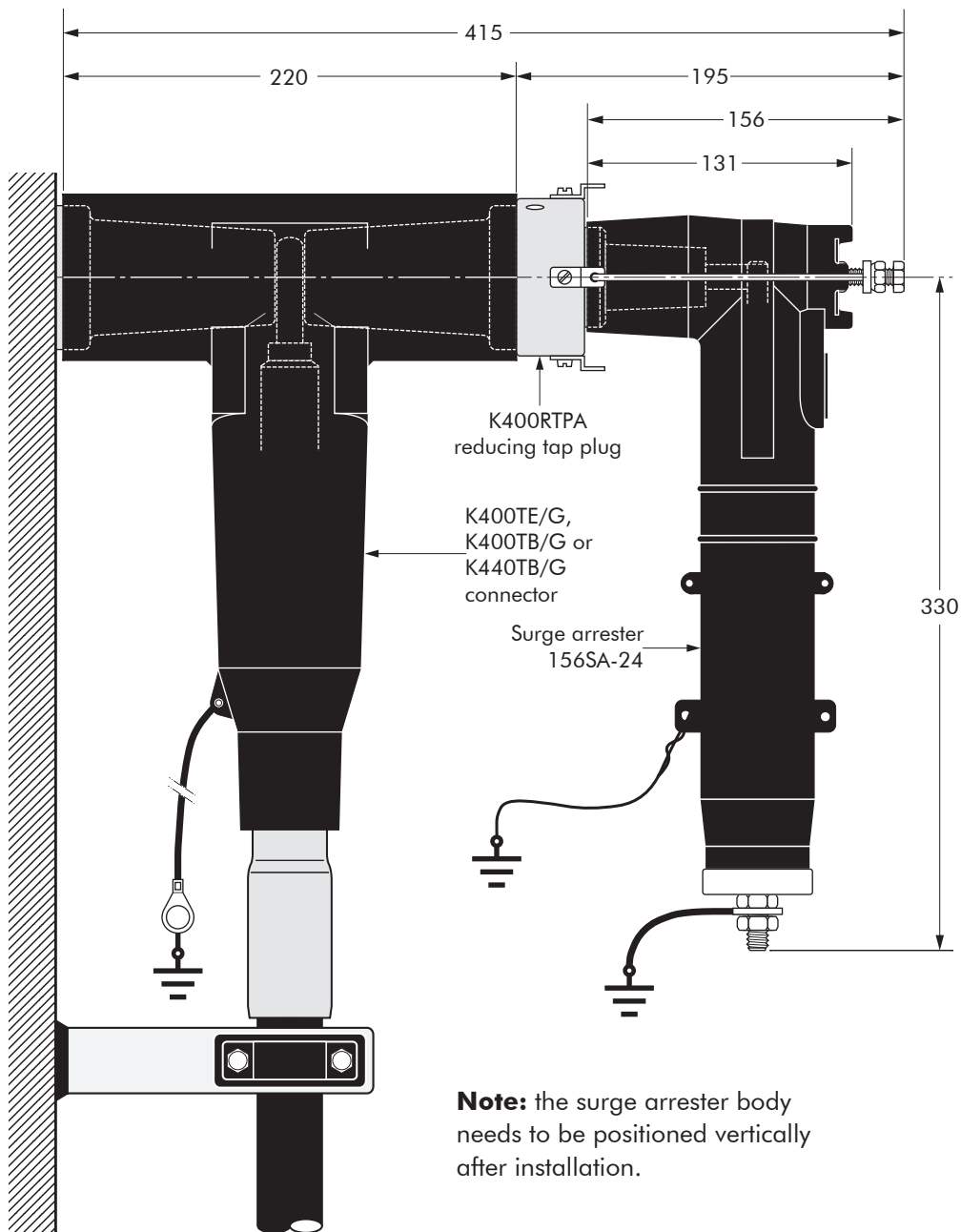

In mm.

ORDERING INSTRUCTIONS

To order the surge arrester, specify the surge arrester type, as described on previous page.

EXAMPLE:

For a maximum continuous operating voltage (r.m.s.) of 21 kV. Order a 156SA-21 surge arrester.